

### FEATURES

- White wire frame bins.
- Recycle bins roll out on laminated platform.
- Precision ball bearing full-extension guides.
- White 27-quart recycling bins.
- Overall size is 19-1/2" high x 11-1/2" wide x 22" deep.
- Designed to fit a B 15–B 24 or B 30–B 48.
- Load rating of 40 lbs.

### PARTS LIST

- A. Waste Bins (2 or 4) 27 qt.
- B. Wire Cages (2 or 4)
- C. Pre-assembled Mounting Board
- D. Mounting Screw Packages
- E. Handle

### TOOLS REQUIRED

- Phillips Head Screwdriver
- Optional
  - Drill with 1/16" Bit for Pilot Holes
  - Pencil

## 2 and 4 Bin Recycler Installation Instructions

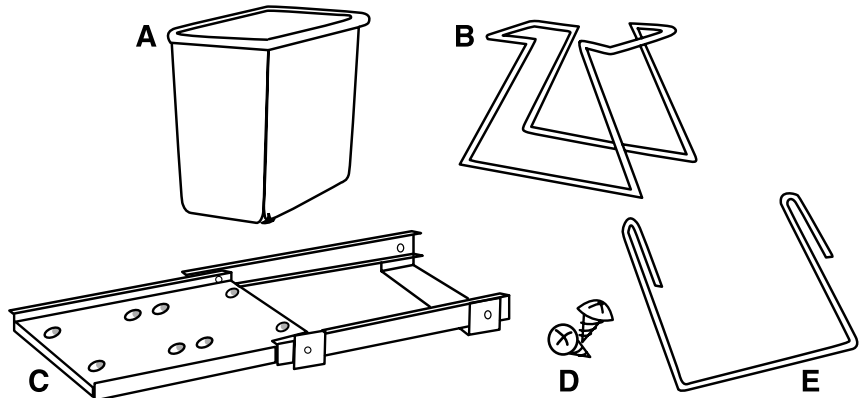

**Step 1** Place slide bracket assembly (C) on cabinet floor. Close door to make sure the unit will not hold cabinet door open. Also, make sure unit will clear door opening when extended. Once position is determined, carefully slide board forward to expose rear mounting holes. Fasten in place using two (2) mounting screws (D). *Optional: mark placement of rear mounting holes with a pencil, remove slide bracket assembly (C) and drill pilot holes for fastening screws.* Place slide bracket assembly (C) in position and fasten.

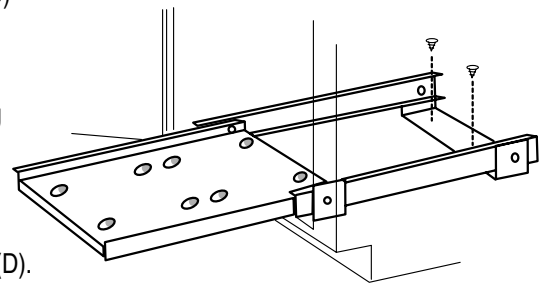

**Step 2** Continue to slide board forward to fully extended position. Take care not to move position of slide bracket assembly (C). Fasten front mounting bracket in place with two (2) mounting screws (D). *Optional: mark placement of screws with pencil and drill pilot holes for fastening screws.* The mounting board (C) should move freely along the track.

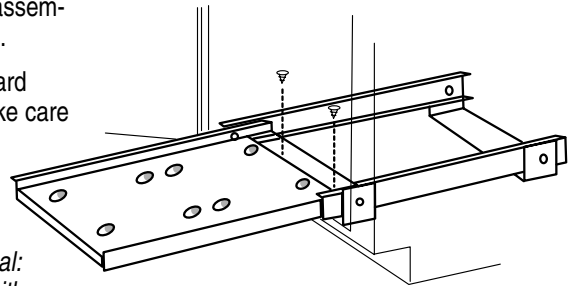

**Step 3** Hold the wire cages (B) over the board and tilt cages so that the back lower wire hooks under the back holding clips provided for each cage. (See detail). Lower the wire cages down onto the board. Snap the cages into the remaining hooks on the mounting board (C). Insert waste bins (A) and engage handle (E) to front of wire cage to complete installation.

